

APPLICATION NOTE 1001 Radiation Immunity of Isolink Optocouplers

Neutron irradiation at two different neutron fluence levels were performed on Isolinks integrated detector optocouplers, OLI300, 400, and 500. The results of the test showed that these types of optocouplers are tolerant to high radiation levels and are suitable for applications in high radiation environments.

OPTOCOUPLER RADIATION RESPONSE

Radiation tests have been performed on optocouplers in the past with various results depending on the optocoupler construction. According to MIL-HDBK-279, "Optical isolators are a combination of a GaAs LED and either a photodiode or phototransistor. The isolators containing phototransistors are more sensitive to irradiation than those containing photodiodes." [1]

Figure 1 illustrates the difference between photodiode and phototransistor style optocouplers. The former distinguishes the optical detection and amplification functions with separate photodiode and transistor stages. This design permits shallower diffusion depths and a smaller transistor base area. Phototransistor optocouplers, on the other hand, maximize the base area for increased optical coupling. This scheme makes the device very susceptible to radiation. [2] At the same radiation level, the device with the smaller exposed sensitive area will experience less radiation damage and hence perform better. [3]

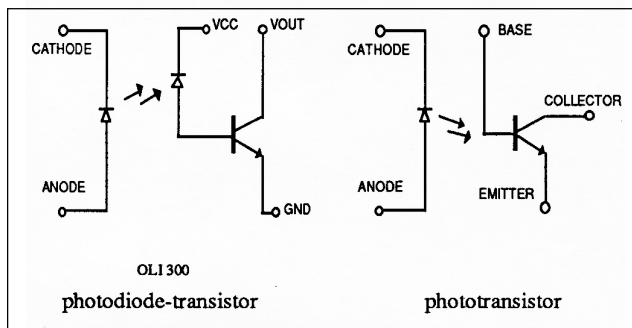

Figure 1. Photodiode and Phototransistor Optocoupler Schematics

Previously published data showed optocouplers with integrated detectors with photodiodes, small transistor base areas, and shallow diffusion depths perform well in radiation tests. No significant operation impairing CTR degradation was observed at the following irradiation levels:

High Speed Logic Gates.

Gamma Total Dose: 3.0×10^3 rads(Si)
Neutron Fluence: 4.0×10^{12} neutrons/cm²

Low Input Current Photodiode-Darlington.

Gamma Total Dose: 3.5×10^3 rads(Si)
Neutron Fluence: 4.0×10^{12} neutrons/cm²

Photodiode,—transistor Optocoupler.

Gamma Total Dose: 3.0×10^3 rads(Si)
Neutron Fluence: 4.0×10^{12} neutrons/cm² [4]

Data from Isolink's neutron irradiation tests showed similar performances.

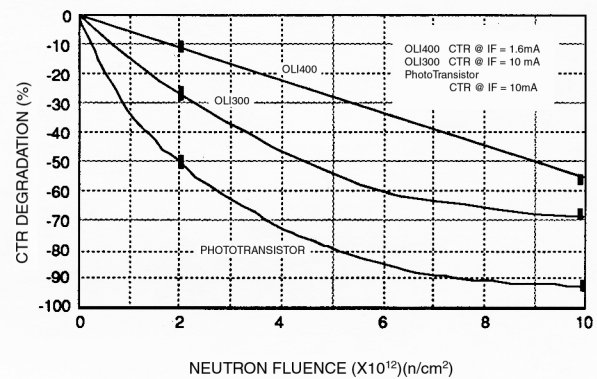

OLI300 Photodiode-transistor
OLI400 Photodiode-darlington
OLI500 Photodiode-high speed logic gate

Figure 2. Isolink Optocoupler Neutron Irradiation Results

For the digital logic gate device, OLI 500, CTR is not as good an indicator of device performance as LED threshold current. The LED threshold current is defined as the input current to the LED that will switch the output detector to the logic low state. After neutron irradiation up to a level of 10^{13} neutrons/cm², all units passed recommended LED input current of 6.3mA. The LED threshold current did increase with increasing neutron fluence levels. The recommended LED input current of 6.3mA represents a 20% guardband over the data sheet switching threshold of 5mA or less.

As expected, phototransistor optocouplers showed much greater CTR degradation, >50% at 2×10^{12} neutrons/cm².

The OLI 300, 400 and 500 optocouplers are well suited for applications with these high radiation environment.

CONCLUSION

This neutron irradiation data reinforces previously published data on the good radiation performance of optocouplers with photodiode detectors with shallow junction diffusion depths and small sensitive geometries. From MIL-M-38510F, the Radiation Hardness Assurance Levels for Neutron Fluence is maximum 2×10^{12} neutrons/cm².

NOTES AND REFERENCES

1. MIL-HDBK-279, 1984
2. Hewlett Packard Application Note 1023.
3. Epstein, A.S., and Trimmer, P.A., "Radiation Damage and Annealing Effects in Photon Coupled Isolators", IEEE Transactions on Nuclear Science, Vol. NS-19, p.391.
4. Hewlett Packard Application Note 1023.

